

ASSEMBLY INSTRUCTION

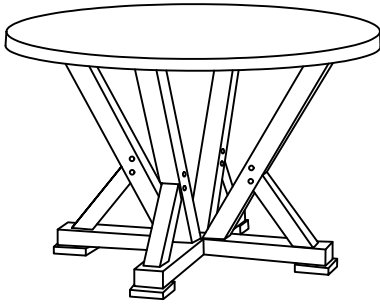





Item No: N300-9191



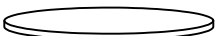



Description: ANNA ROUND DINING TABLE



IMPORTANT NOTE :

- Place all wooden parts on a clean and smooth surface such as a rug or carpet to avoid the parts from being scratched.
- Check to be sure that you have all parts and hardware.
- Remove all wrapping materials, including staples & packing straps before you start to assemble.
- Do not tighten all screws/bolts until all completely assembled.
- Keep all hardware parts out of reach of children.

PARTS LIST		
NO.	COMPONENT	QTY.
1	TABLE TOP 	1 PCS
2	UPPER MOUNTING PLATE 	1 PCS
3	LOWER MOUNTING PLATE 	1 PCS
4	LEG ASSEMBLY 	4 PCS
5	UPPER LEG BASE 	1 PCS
6	LOWER LEG BASE 	1 PCS

HARDWARE LIST		
NO.	DESCRIPTION	QTY.
A	ALLEN KEY M4 x 100MM 	1 PCS
B	JCBC BOLT M6 x 35MM 	4 PCS
C	JCBC BOLT M6 x 80MM 	8 PCS
D	SPRING WASHER M6 x 13MM 	12 PCS
E	FLAT WASHER M6 x 19MM 	12 PCS
F	ADJUSTABLE LEG LEVELER 	4 PCS
G	METAL BRACE 200 x 20MM 	2 PCS

STEP 1

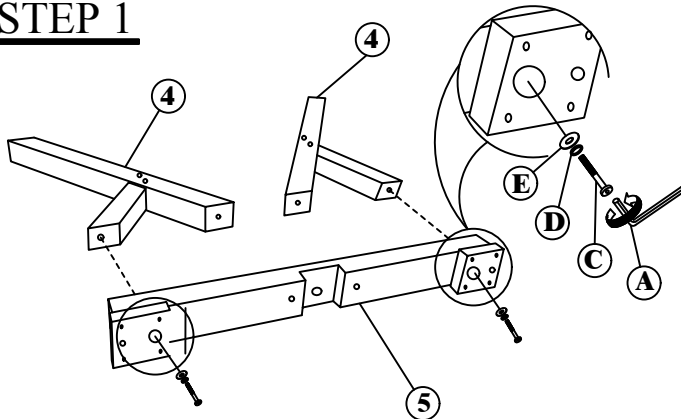

STEP 2

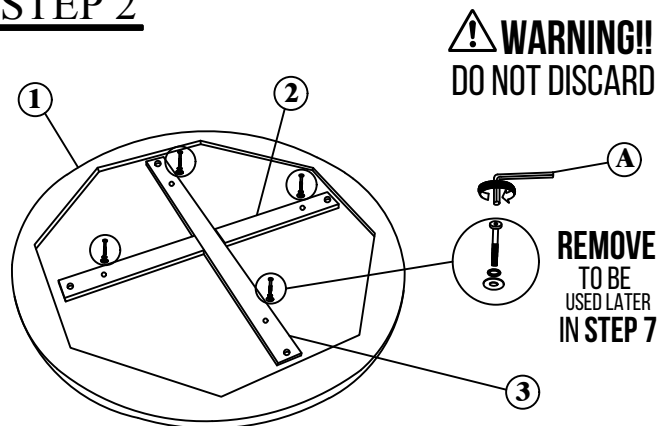

STEP 3

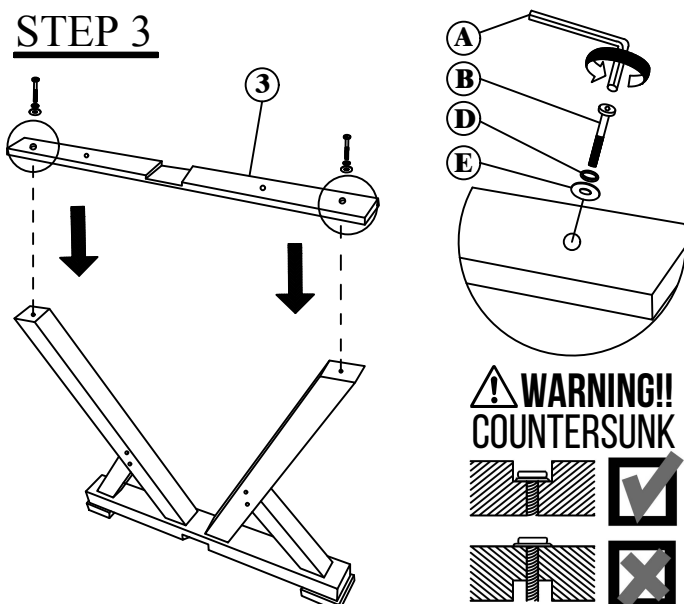

STEP 4

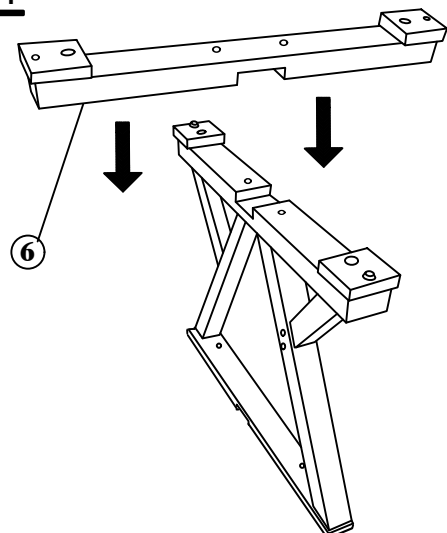

STEP 5

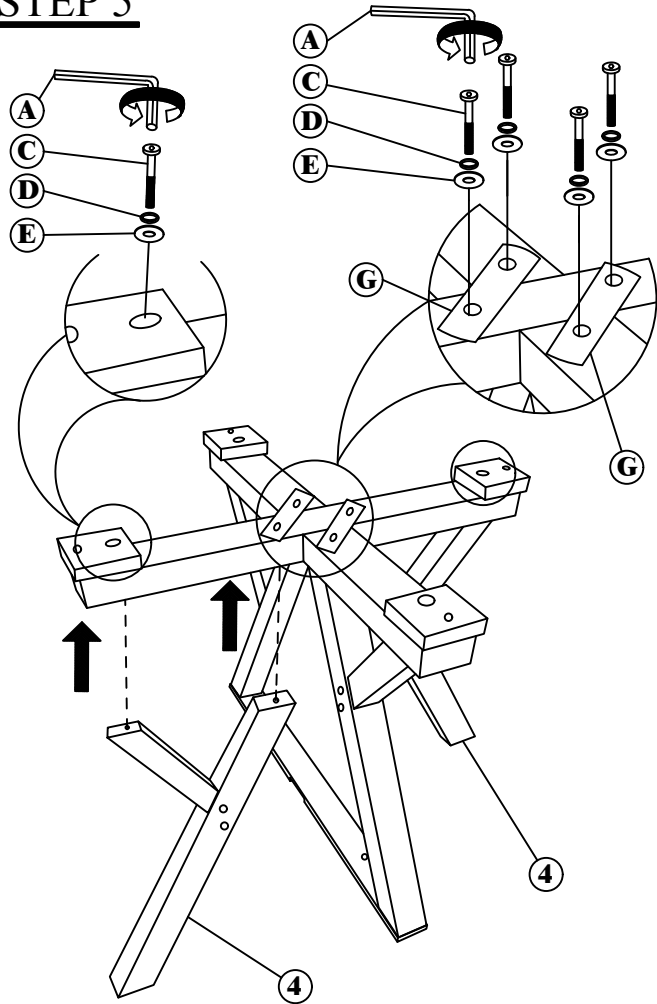

STEP 6

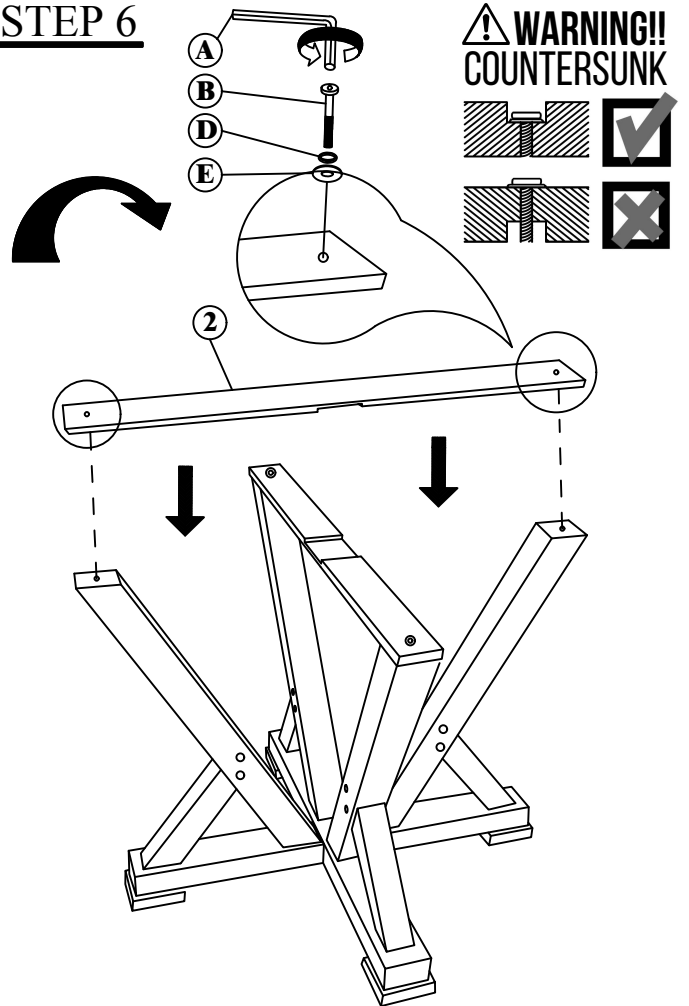

STEP 7

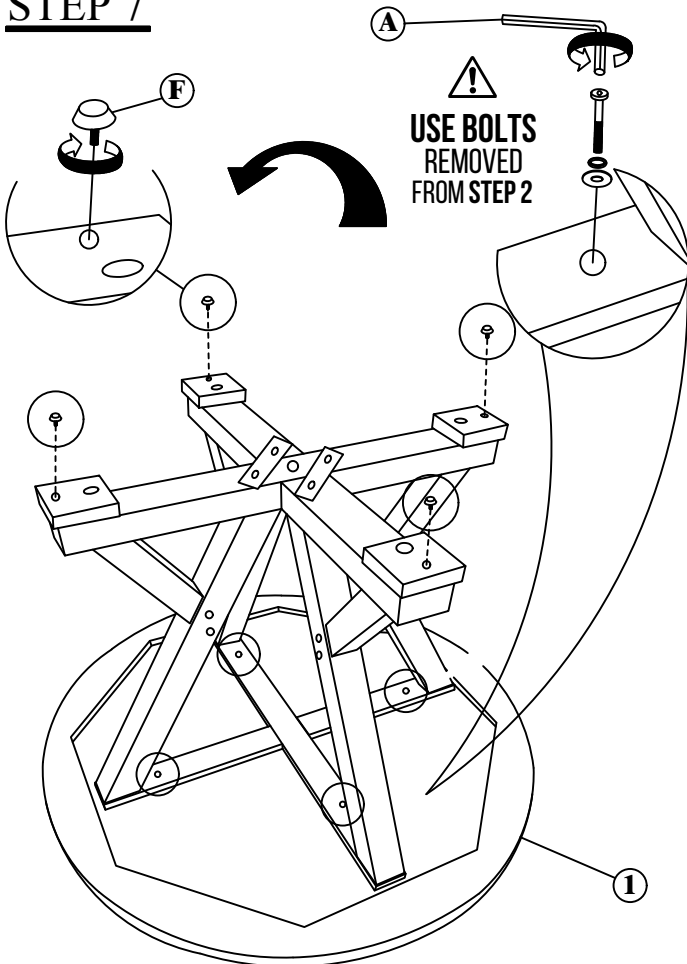

STEP 8

